

Critical Features in Fuel Cell Testing

ElectroChem, Inc.

400 W. Cummings Park
Woburn, Mass 01801 USA



www.fuelcell.com

781-938-5300

Fuel Cell

Convert Chemical Energy into Electrical Energy

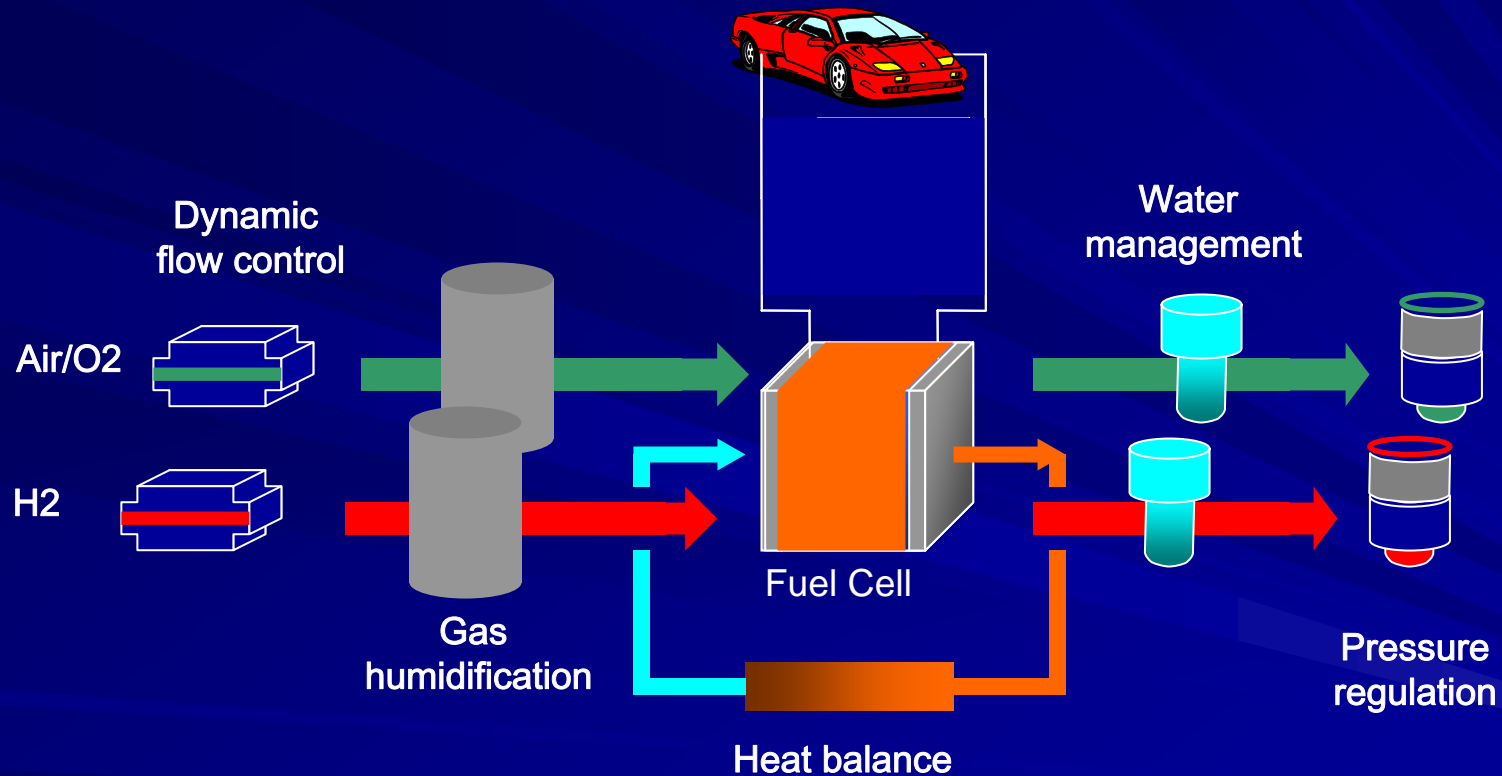

Critical Fuel Cell Testing Control Variables

- Fuel Supply
- Humidity
- Temperature
- Pressure
- Stability & Repeatability
- Safety

Response to Current Followed Fuel

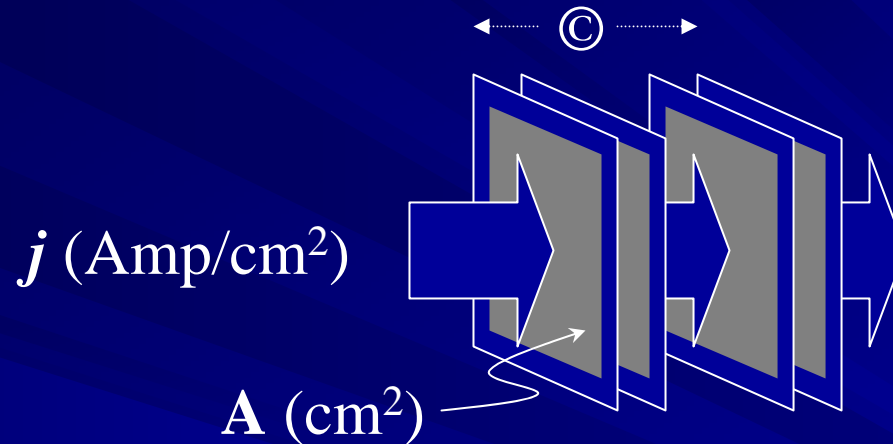

$$\dot{m} \text{ (mole/sec)} = \frac{j A \textcircled{C}}{n F}$$

J : current density

A : electrode size

\textcircled{C} : number of cells

n : electron transfer

F : Faraday constant

1 Amp \approx 7 cc/min of H₂ (STP)

How Important is Capacity vs. Accuracy ?

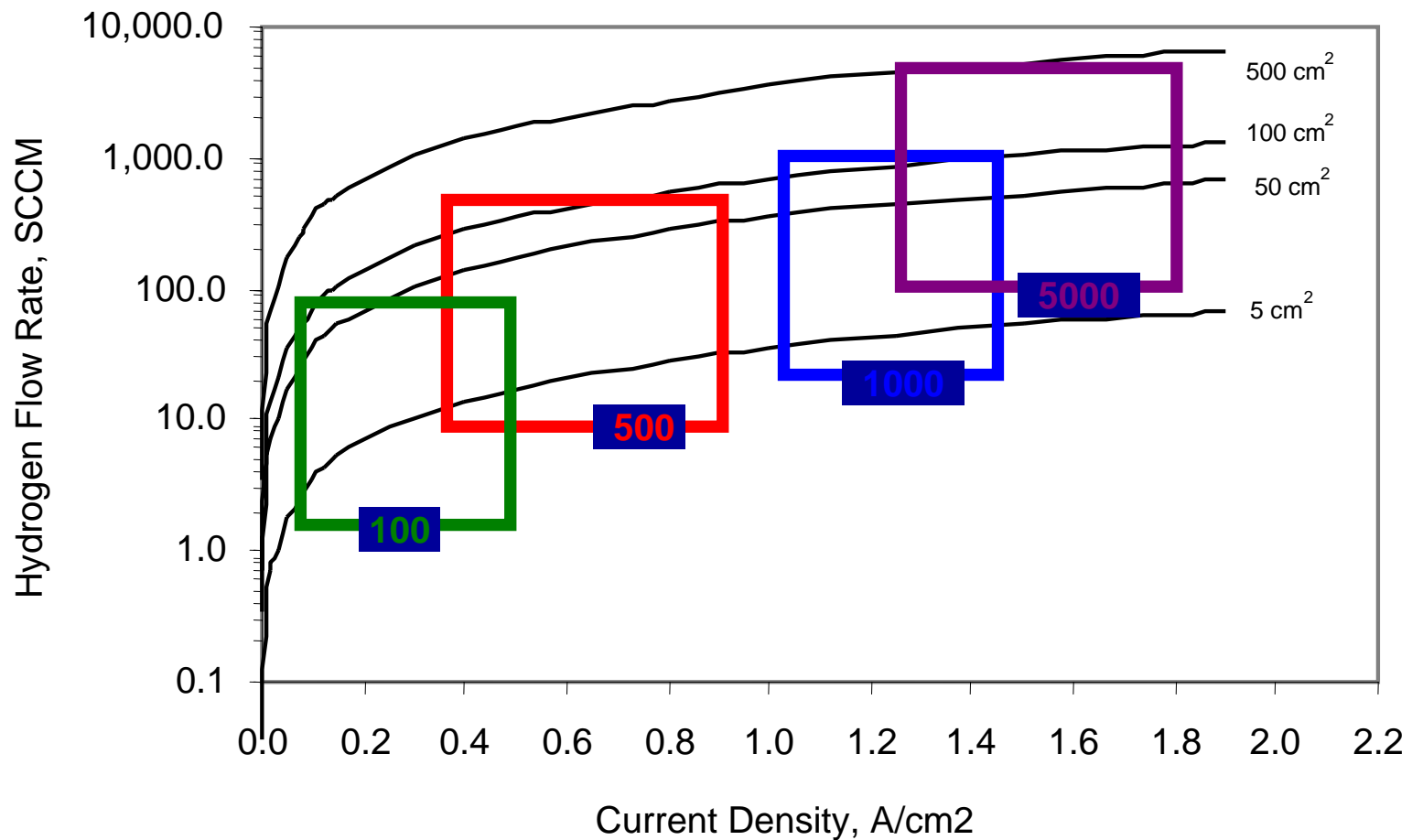

Different Flow Control Mechanism vs. Different Fuel Efficiency

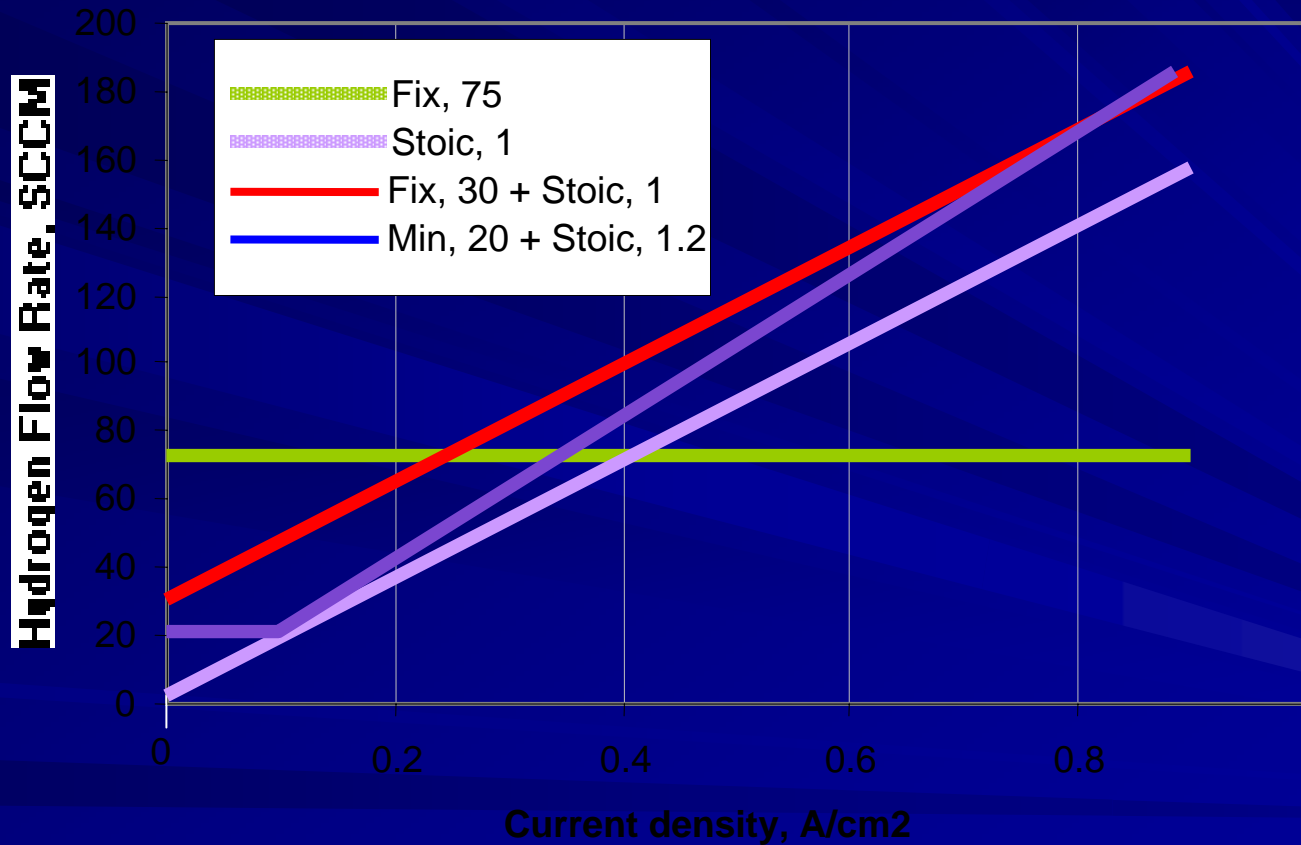

Water Formation and Distribution

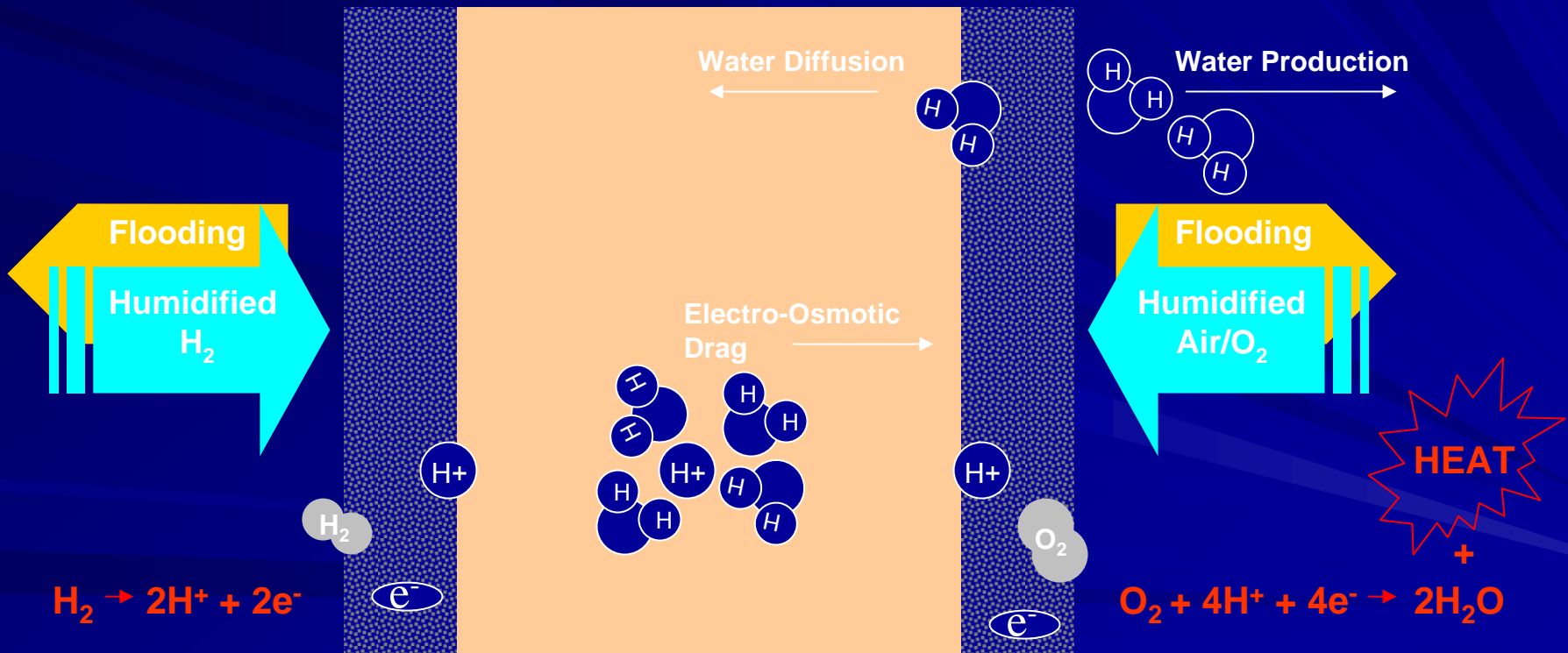

Obtain Accurate and Responsive Humidity Measurement

$$\text{Humidity Ratio} = 4.3E-2 e^{(0.06T)}$$

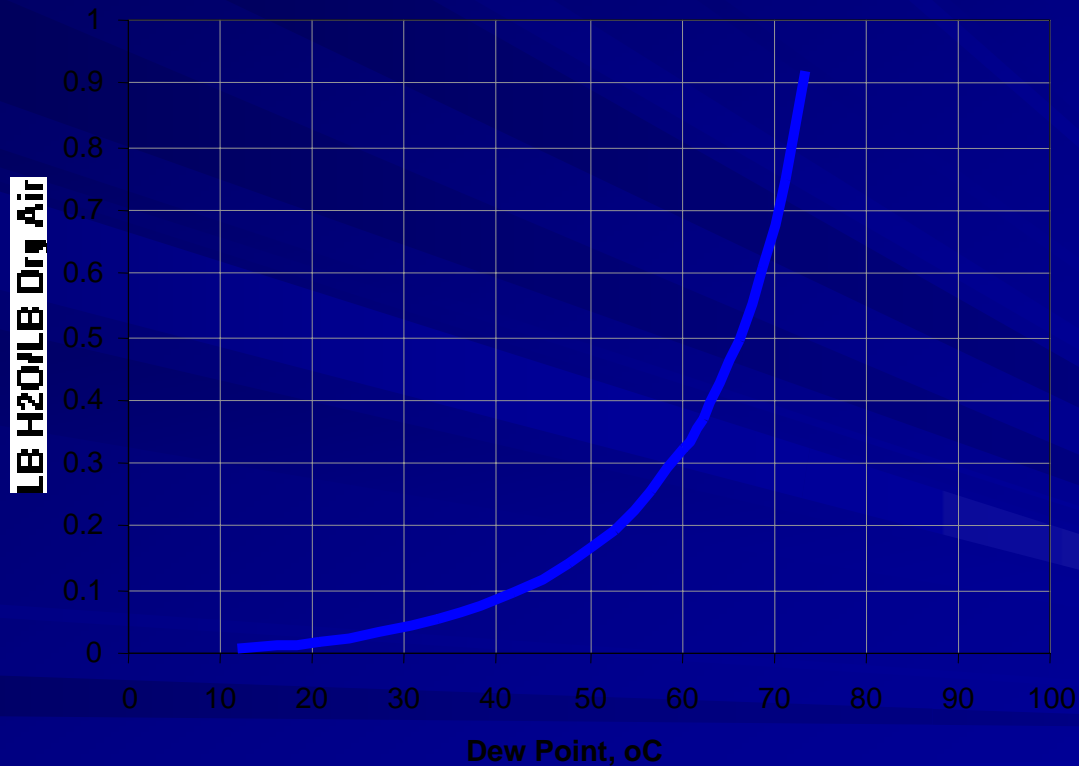

How Many Temperature Controllers Needed?

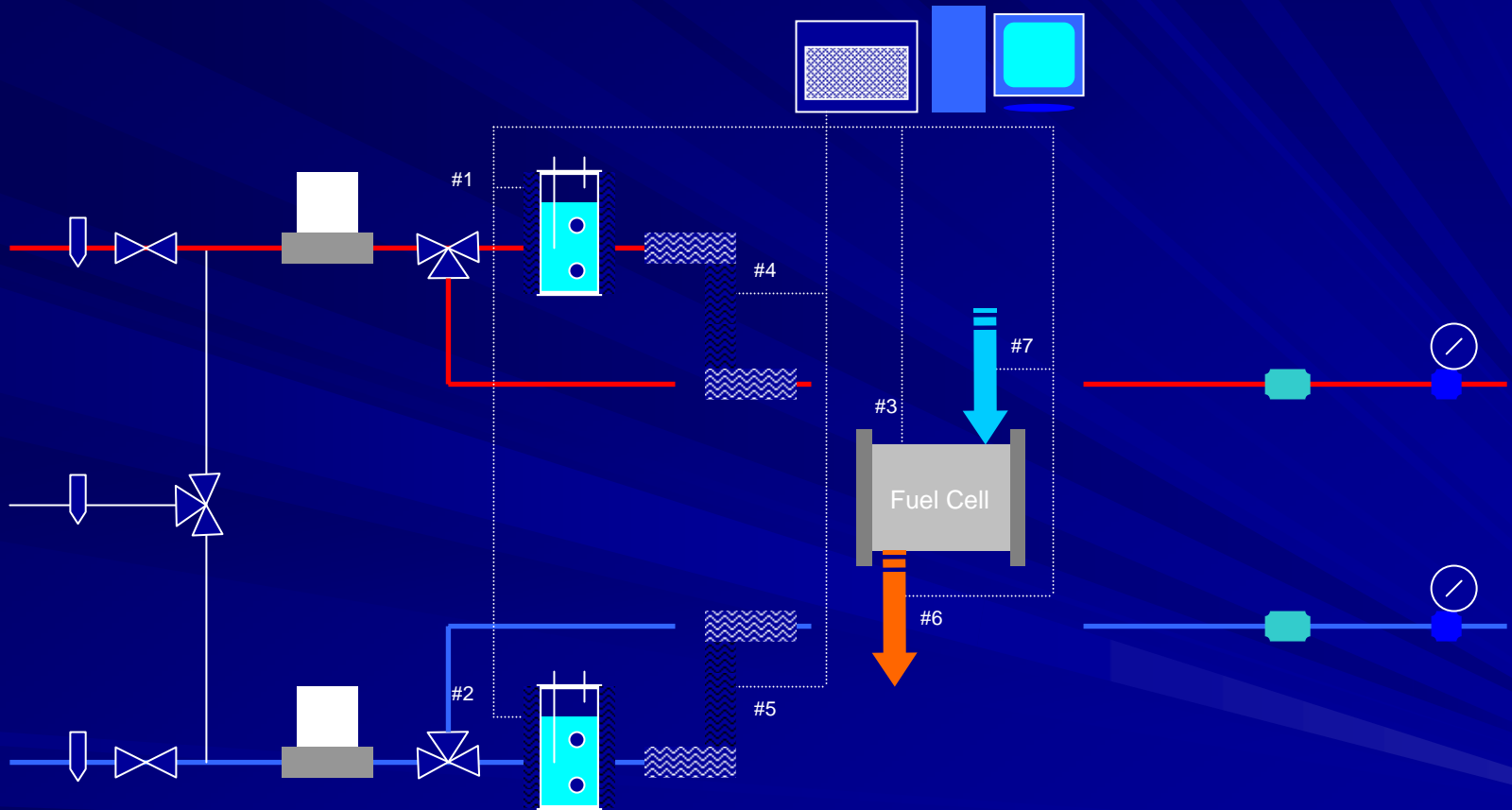

#1: Anode humidifier temperature
#2: Cathode humidifier temperature

#3: Fuel cell temperature
#4: Anode gas inlet temperature
#5: Cathode gas inlet temperature

#6: Coolant inlet temperature
#7: Coolant outlet temperature

What Pressure Do You Measure?

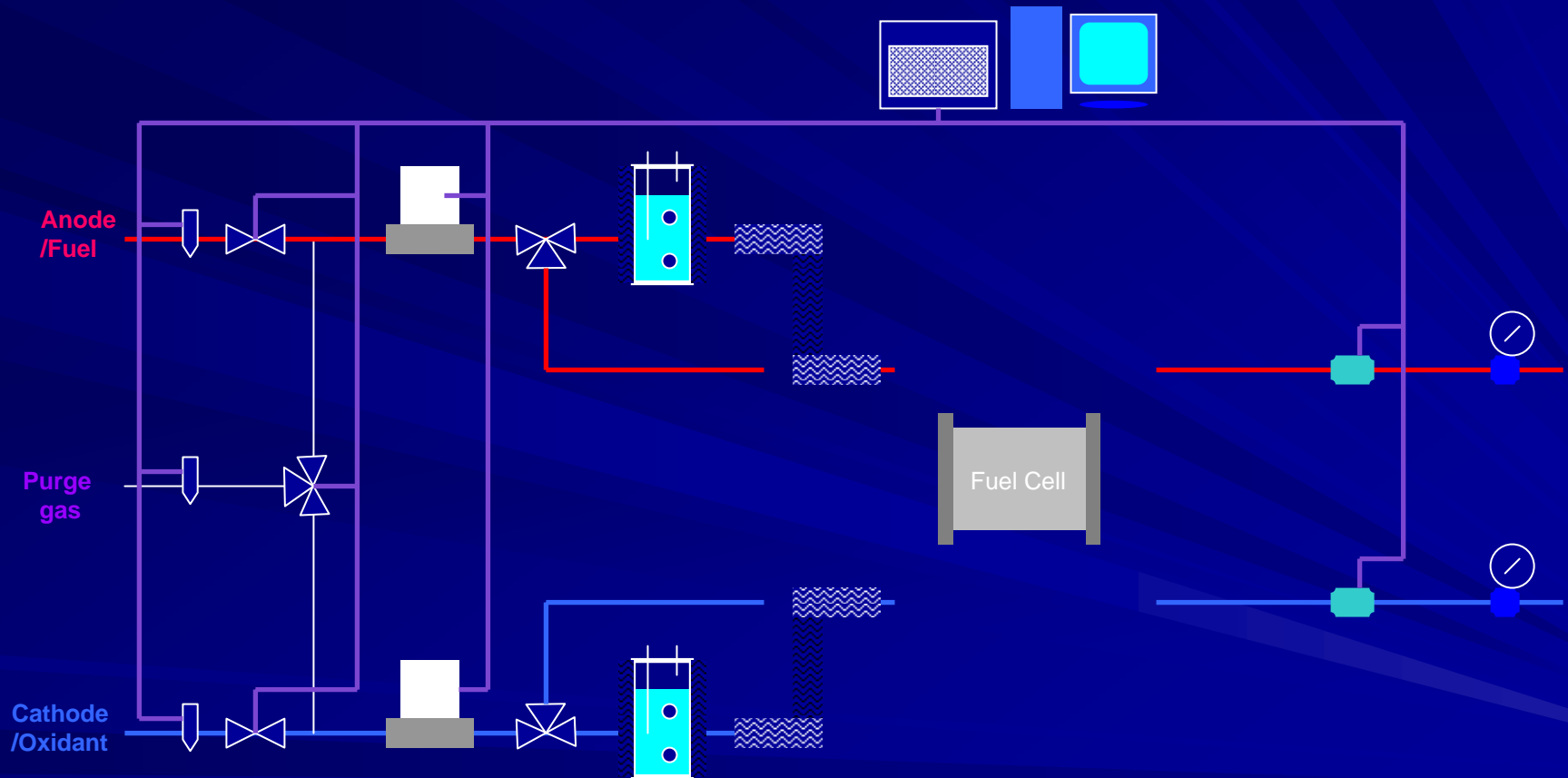

Functional and Intuitive Operation Interface

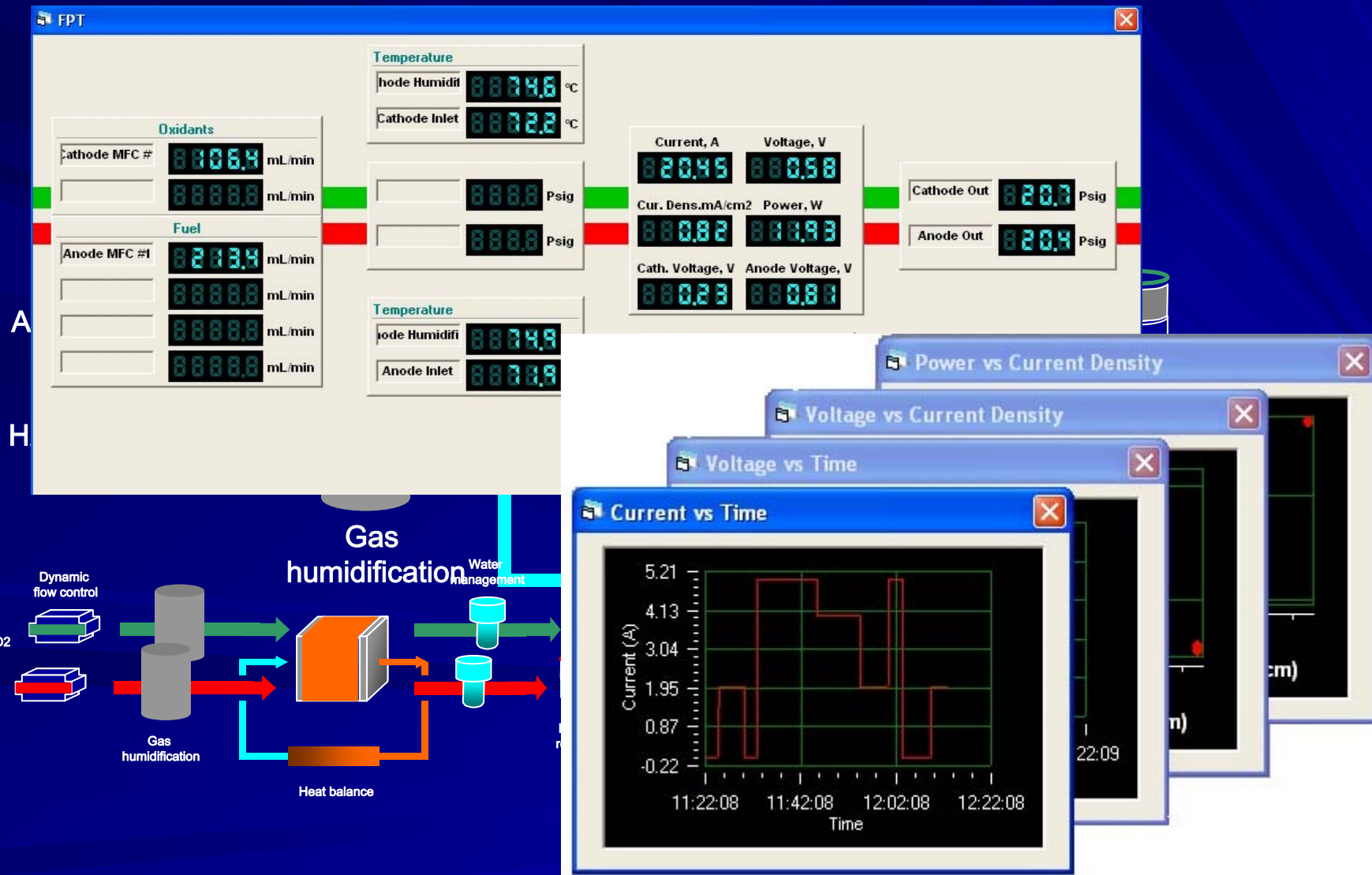

Repeatable

- Independent test protocols
- Independent test configuration files
- Programmable testing parameters
 - Constant (I, V, Power)
 - Step Change (I, V, Power)
 - IV performance curve
 - Scanning rate (mV/s)

Create Programmable Test Protocol Files

Configuration C:\PowerStation_Config\FC2

Profile C:\PowerStation_Profile\prf_4

Logging C:\PowerStation_Logging\02

Logging Rate 0 25 50 75 100

Profile

Test #	Type	Description	Cycles
1	Constant Current	Step	1

Seq. #	Dur. or Rate	Type	Ending Value
1	2	Minutes	0
2	0	Minutes	2
3	5	Minutes	2
4	0	Minutes	8
5	10	Minutes	8
6	0	Minutes	0
7	3	Minutes	0

Test #	Type	Description	Cycles
2	Constant Current	Ramp	1

Seq. #	Dur. or Rate	Type	Ending Value
1	2	Minutes	0
2	1	dx/dt(Minutes)	15
3	-1	dx/dt(Minutes)	0
4	5	Minutes	0

Add...

Automatic Testing Profiles

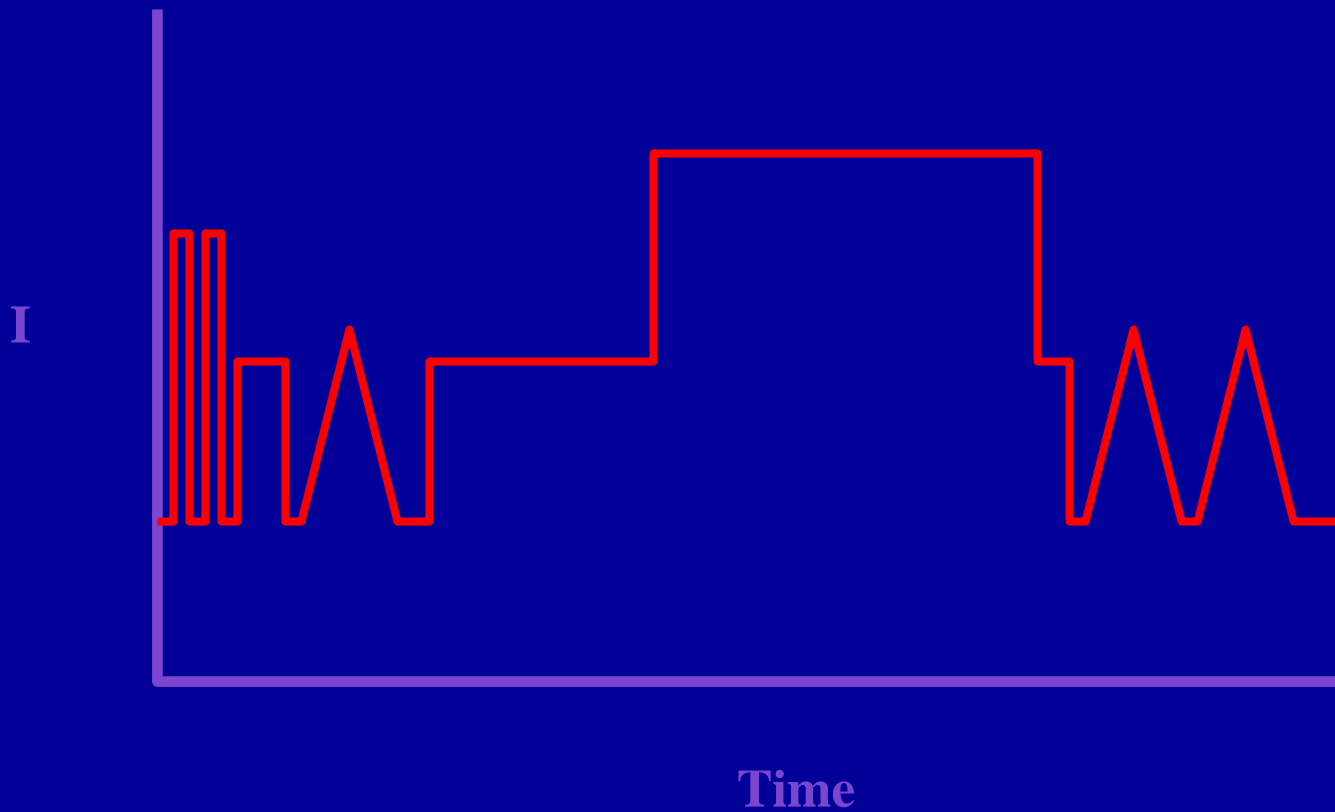

Expandable

- Single and Multiple control channels
- DMFC Test
- Reformat Test
- AC Impedence Diagnostic

Gas Distribution System Upgrade

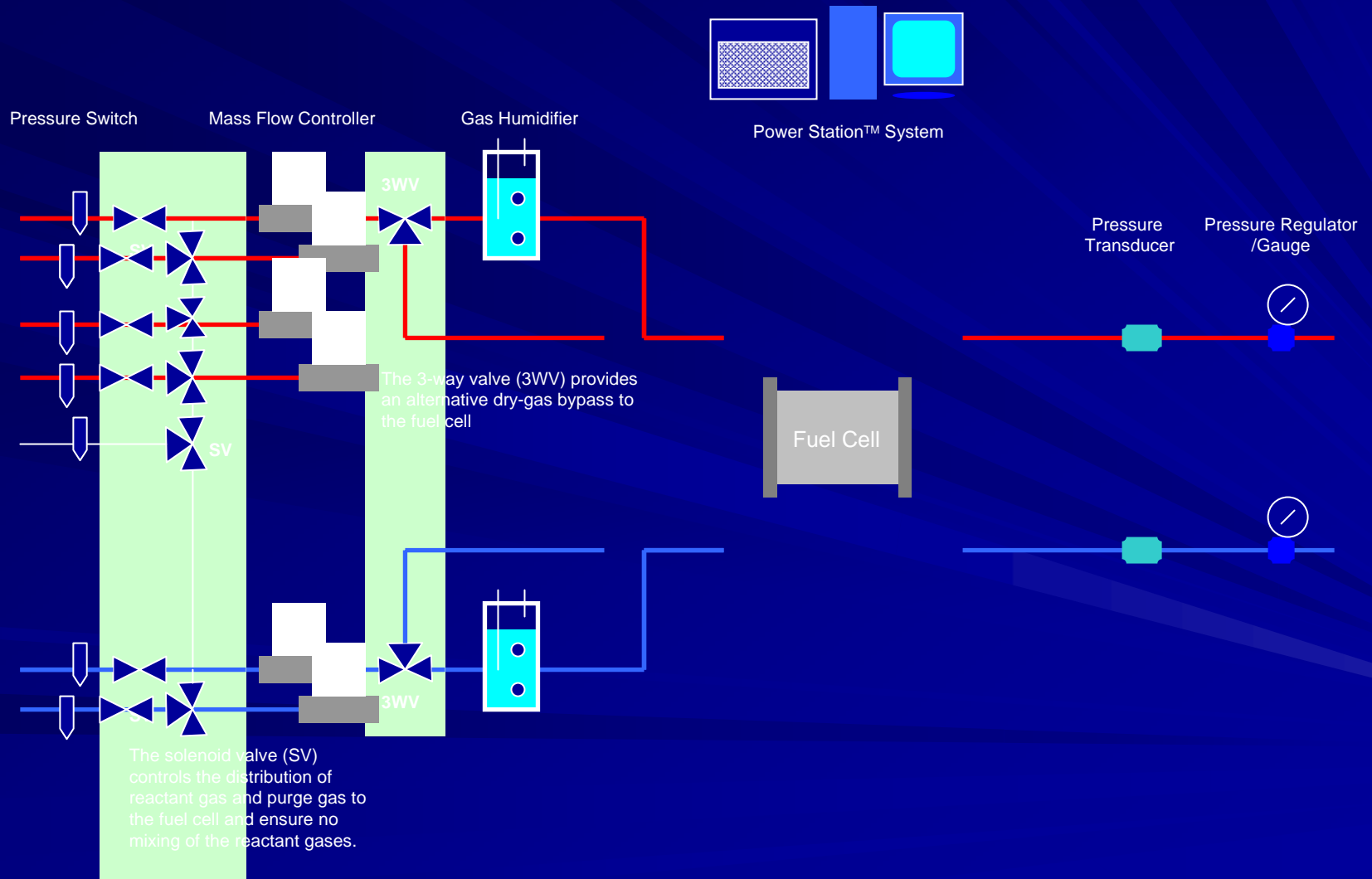

Safety Consideration

- User Selectable
 - Over Temperature
 - Low Cell Voltage
 - Low Supply Gas Pressure
- Communication Error
- Automatic Purging
- Hardwired Interlock

Summary

- **Repeatable and Reliable test procedures are required to verify fuel cell base line performance and changes in performance**
- **Simulation and Control of all fuel cell operating variables must be Repeatable**
- **Flexible test Instrumentation provide both stable operation and a variety of operation conditions**
- **Design of Fuel Cell Test Profile capable of precondition the cell and cycle testing through a series of test profile**
- **The test system must also allow Cost Efficient Data Collection**



ElectroChem, Inc.

ElectroChem
the power behind

www.fuelcell.com